

MEASURING THE COHERENCE FUNCTION WITH THE HP 3582A SPECTRUM ANALYZER

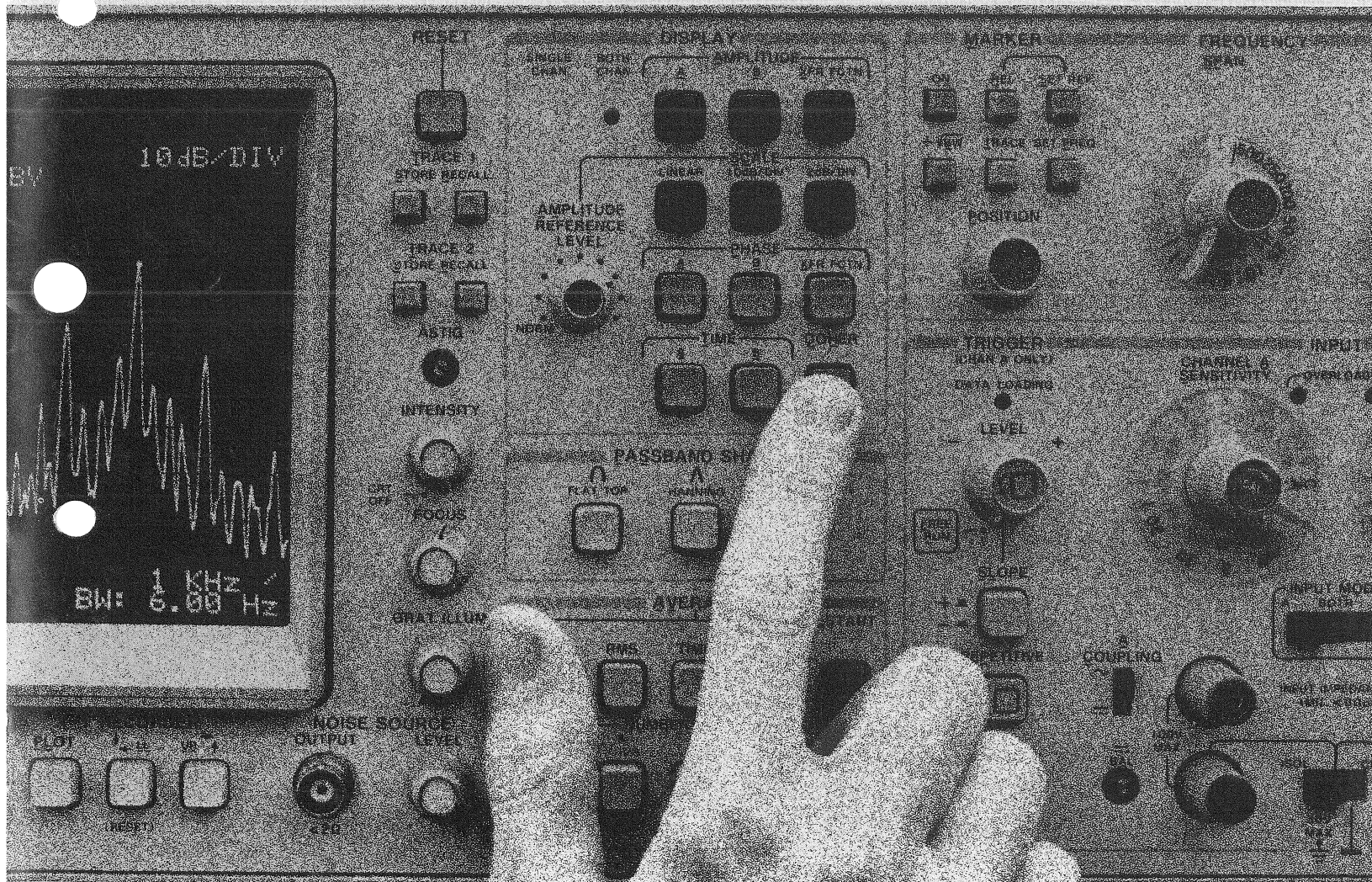

FOREWORD

The Fast Fourier Transform algorithm and the development of powerful LSI devices are producing a revolution in the design of signal analyzers. The 3582A Low Frequency Spectrum Analyzer is based on this new technology and provides both greatly increased measurement speed and several kinds of measurement not available in traditional analog instruments.

One of the new measurements available in the 3582A is called the coherence function. If you have encountered problems with noise when measuring transfer functions, the coherence function will help to pinpoint where the difficulty lies. Similarly, if you are trying to determine whether one signal is wholly or partly responsible for an-

other, the coherence function will help because it indicates causality.

Although the coherence function has been a relatively unfamiliar statistical parameter, its usefulness is becoming apparent to the growing number of persons who need to analyze low frequency signals. Having the coherence function internally computed and available for display in the 3582A and similar instruments will, of course, increase interest in understanding its properties. This application note is intended both as an initial contribution to this understanding and as an encouragement to 3582A users to utilize the coherence function in solving their measurement problems.

THE HEWLETT-PACKARD MODEL 3582A SPECTRUM ANALYZER

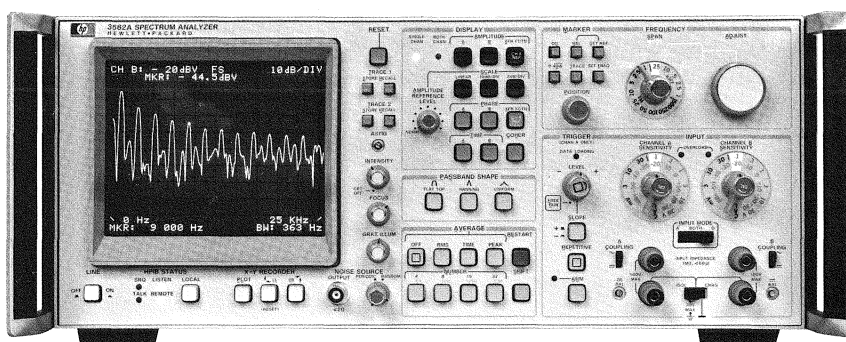

The HP 3582A is a spectrum analyzer covering the frequency range of DC to 25 kHz. Although it is a FFT-based, digital instrument, a special design effort has made it as straightforward to use as a conventional swept analyzer. With dual measurement channels it is possible to measure transfer function gain and phase, as well as the coherence function. A built-in random or pseudo-ran-

dom noise source, whose spectrum tracks the analysis range, is a useful measurement stimulus. Band Selectable Analysis enables narrowband, high resolution analysis to be applied to any portion of the frequency range. The instrument comes equipped with a flexible HP-IB interface for control and two-way data transfers.

TABLE OF CONTENTS

	Page
Section 1: Some system measurement problems	1
Transfer function measurements	
Cause-effect relations	
This section describes two classes of measurements and indicates the role of the coherence function in each.	
Section 2: Introducing the coherence function	2
What is it?	
The role of the coherence function in spectrum averaging	
A note of caution	
Summary of how the coherence function is used	
A brief discussion of the coherence function, its properties and its interpretation is followed by the reasons why it is usually associated with spectrum averaging. A possible problem in interpreting the coherence function is explained.	
Section 3: The coherence function and the 3582A	3
Transfer function measurements	
Causality measurements	
A specific procedure for using the coherence function to assess the validity of measured transfer functions is given. Another procedure is outlined for measurement of the coherence function itself. For each case, 90 percent statistical confidence tables are provided for quantitative interpretation of the measurements.	
Section 4: Experimental examples using the coherence function	5
Example 1: monitoring a transfer function measurement	
Example 2: dual-input system with random signals	
Here are the results of two experiments which illustrate the two principal roles of the coherence function.	
Appendix: Definitions and interpretations	8
Linear spectra and power spectra	
Mathematical definition of the coherence function	
Interpreting the coherence function as a power ratio	
Interpreting the coherence function as a correlation coefficient	
The use of the cross power spectrum to calculate transfer functions	
Mathematical definition and interpretations of the coherence function were left out of the main body of the application note, but are included here for fuller understanding.	
Bibliography	9

Section 1: Some system measurement problems

Transfer function measurements and the coherence function

Many engineering problems are solved through determining how signals are modified in amplitude and phase as they pass through a system. Transfer function measurement, as this is called, is often made with a network analyzer. This is a specialized instrument which provides a driving signal and can measure the input/output amplitude ratio and phase shift over a band of frequency. Figure 1 shows a typical setup. An excitation signal, such as a swept sinewave or a broadband source, is applied to the input of the system being checked. The system output—its response to the excitation—is measured and the transfer function is calculated. For the calculation, both input and output are in the form of frequency functions.

In “real life” situations, sometimes complications come up which render this kind of measurement inaccurate or even useless. The problem is the presence of additional signals in the output of the system. One kind of disturbing signal is noise, whether internal to the system or external. Another disturbance takes the form of distortion products generated by system nonlinearities. In either case, the disturbing signals affect the accuracy of measuring the linear input/output relation.

Figure 1.

Measuring a system's transfer function

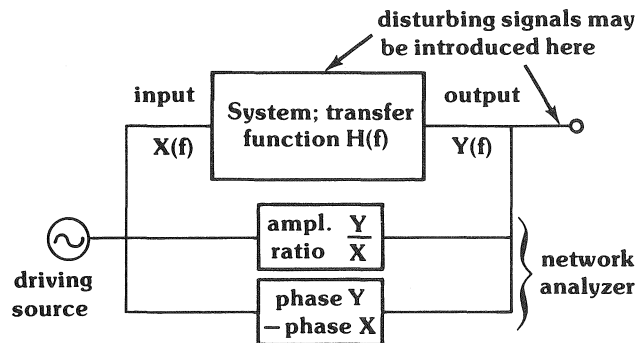

It is evident that determining the transfer function $H(f)$ by calculating the spectral ratio $Y(f)/X(f)$ will lead to irrecoverable errors whenever there is a disturbing signal included with the output $Y(f)$. The 3582A reduces these errors through a computational technique: it uses the cross power spectrum (see appendix) and spectrum averaging. The question remains, however, how many averages are needed to attain a desired accuracy?

Another kind of transfer function problem is the multiple-input system represented by Figure 2. In this case, the signal Y at the output is a composite of energy from several sources X_1, X_2 , etc. This situation may be intentional or unintentional. We want to determine the transfer function from each input to the output; in general, these are not identical. An obvious way to do this is to turn off

all sources and to apply the network analyzer to each path in turn. However, this can't always be done or is often undesirable (vibration measurement on a 4-engine aircraft, for example). Thus, it becomes necessary to measure the desired transfer function in the presence of signals from other sources. The 3582A can perform this measurement, but, again, we have to answer the question of how many spectra must be averaged to achieve a given accuracy.

We shall show in Section 3 how the coherence function may be used to determine the number of averages needed.

Figure 2.

A multiple-input system

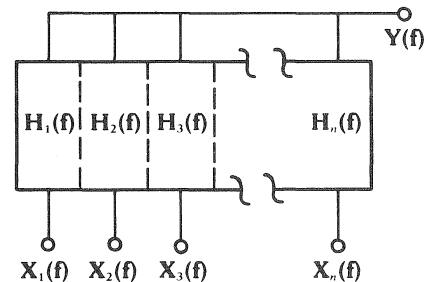

Cause-effect relations and the coherence function

Figure 2 serves as the model for another engineering problem. In this case, the exact shape of the transfer function between any input and the output is not needed. Rather, we are looking for causality; that is, we want to determine how much each source influences the observed output Y . For instance, which machine in a shop is most responsible for the noise at a given location? Which is least responsible? Traditionally, this measurement, when made at all, has relied on determining the cross-correlation function between the suspected source and the output signal Y . The coherence function will also reveal these causality relations, but it has an additional advantage over the cross-correlation function. The cross-correlation function is a function of time, and its maximum value corresponds to the approximate time delay (that is, propagation time) between the source and the observed effect Y . However, the coherence function is a function of frequency, and its maximum values occur at the **frequencies** where the greatest transfer of energy is taking place. The remedies used to suppress interference (noise, vibration, etc.) depend on the frequency distribution of the interference. Therefore, the coherence function not only reveals the degree of causality but is a direct aid in choosing the best means to solve the interference problem.

An example of the use of the coherence function in this application will be given in Section 4.

Section 2: Introducing the coherence function

What is it?

Leaving the mathematical definition for the appendix of this note, we can summarize the important features of the coherence function:

- a) it is a dimensionless, frequency-domain function.
- b) its range of values is 0 to + 1.
- c) at **each** frequency, it represents the fraction of the system output power directly related to the input.

With these properties, the coherence function is rather like a cross-correlation function in the frequency domain. (This interpretation is developed in the appendix.) If the system in Figure 1 has no contaminating noise, or there is only one input to the system in Figure 2, the coherence function is + 1 at every frequency where there is any output energy.

On the other hand, if $X = 0$ or $H = 0$ at some frequency (so that noise is the only output), the coherence function is zero for that frequency.

When the coherence function is less than unity, at least one of the following conditions exists:

- a) there is noise contaminating the measurement
- b) the system is nonlinear (and generating energy at additional frequencies)
- c) other inputs are present in the system.

The role of the coherence function in spectrum averaging

In reading material on the coherence function, one soon notices that it is almost always discussed and used in the context of spectrum averaging. There are two principal reasons for this. First, in some situations there is unwanted noise contaminating the measurement—such as the transfer function measurement. To compute the transfer function, the 3582A makes use of the cross-power spectrum and relies on averaging to increase the signal-to-noise ratio. The role of the coherence function in this case is to give an indication of how many averages are needed to achieve a given statistical accuracy.

The second reason for the association of the coherence function with spectrum averaging concerns the use of the FFT algorithm. When the FFT is used to calculate the coherence function, a single transform results in a value of unity for the coherence function regardless of its true value. A number of transforms must be averaged to produce a useful (that is, accurate) estimate of the coherence function itself.

For these reasons, the 3582A provides computation and display of the coherence function only in conjunction with the power spectrum averaging routing (called “RMS” averaging on the front panel).

Statistical accuracy vs. instrument accuracy.

In discussing accuracy improvement through averaging, we must point out that we mean **statistical** accuracy and not instrument accuracy. Statistical errors occur because we can measure only a finite sample of a signal. In general, the longer the sample, the smaller is the statistical error. Averaging is one way of measuring a longer sample.

On the other hand, there is always the problem of instrumentation errors. They exist for the traditional reasons of component tolerance, aging, misadjustment, etc., and they are usually not reduced by averaging. So the discussion of the role of the coherence function in accuracy improvement refers only to statistical accuracy.

For further discussion of the use of spectrum averaging in the measurement of noisy or noise-like signals, we refer the reader to the companion Application Note, 245-1 “Signal Averaging With the HP 3582A Spectrum Analyzer.”

A note of caution

As useful as the coherence function may be in resolving some of the measurement difficulties mentioned, it is not a panacea. There is one situation in particular in which the user must guard against misinterpreting the information contained in the coherence function. This occurs most commonly in causality measurements and often involves signals at AC powerline frequencies.

For example, suppose the problem is that AC magnetic flux is leaking into a sensitive electronic circuit, and that one of several nearby transformers is suspected to be the culprit. Using appropriate transducers and the 3582A, we measure the coherence function between the circuit and each transformer. **Each** measurement produces a value of + 1 at the powerline frequency and several of its harmonics. The experiment is saying that **each** transformer is completely responsible for the interference! This anomaly is caused by the fact that every transformer is wired to the same power source, which is the primary source of the disturbance.

The principle to remember is: if two or more sources are related to (caused by) a primary source, then the coherence function will not reveal the secondary causal relations we want to determine.

This can be a difficult problem in some situations. It can **sometimes** be solved through the more complex techniques of multiple coherences (Ref. 3). Of course, if we can arrange to turn on the sources one at a time, the solution is easy!

Summary of how the coherence function is used

In Section 1 we discussed two broad classes of measurements in which the coherence function has an important role: transfer function measurements and determining causality. The contribution of the coherence function to each of these may be summarized:

- a) Transfer functions. The basic technique used to improve the measurement accuracy is spectrum

averaging. The coherence function is an indicator by which we can determine the number of averaged spectra needed to achieve a desired accuracy.

- b) Causality. At every frequency being analyzed, the coherence function directly indicates causality. Its value is interpreted as the fraction of system output power that can be attributed to the input.

Section 3:

The coherence function and the 3582A

In this section, we outline suggested measurement procedures for the 3582A. Both transfer function and causality measurements are included. There are also tables to help you determine the statistical accuracy of your measurement.

Transfer function measurements

When noise or other signals unrelated to the input are present in the output, the 3582A Transfer Function routine can employ RMS averaging to improve the statistical accuracy. In this note, we use the “90% confidence limit” approach to quantify the accuracy. This means that there is a band of values (given in dB) around each measurement of the transfer function amplitude. The true amplitude will lie within the band in 9 out of 10 measurements **on the average**. For transfer function phase, the idea is the same, but the measurement band is given in degrees.

The following procedure can be used to detect regions of noise contamination and to get acceptable statistical accuracy in measuring the transfer function.

- a) Set up the transfer function routine on the 3582A, using the built-in noise source or another drive signal which covers the frequency range of interest.
- b) Execute 16 or more RMS averages.
- c) Display amplitude and coherence (or phase and coherence).

- d) Use Table 1 to determine whether the measurement is sufficiently accurate in regions where the coherence is low or where high accuracy is desired. If not, more spectra can be averaged by pressing a higher-valued “number of averages” button.
- e) Repeat if necessary.

Causality measurements

For measuring causality the desired result is the value of the coherence function itself. If this is not +1, then some averaging must be performed in order to get a statistically accurate measure of its true value (see Section 2).

This procedure should yield acceptable results:

- a) Set up the coherence measurement on the 3582A, connecting the source being investigated to Channel A and the system output to Channel B.
- b) Execute 16 or more RMS averages.
- c) Display the coherence function. Using Table 2, determine whether the measurement is satisfactory. If not, continue averaging by pressing a higher-valued “number of averages” button.
- d) Repeat as necessary.

Table 1

90% confidence limits on the measurement of the amplitude $|H|$ and phase ϕ of transfer functions, as a function of the measured value of coherence and the number of averages.

Measured value of coherence function	Number of Averages				
	16	32	64	128	256
0.2	+ 5.2	+ 3.8	+ 2.8	+ 2.1	+ 1.5
	- 14.6	- 7.1	- 4.2	- 2.7	- 1.8
	(± 54)	(± 34)	(± 23)	(± 16)	(± 11)
0.3	+ 4.2	+ 3.1	+ 2.2	+ 1.6	+ 1.2
	- 8.4	- 4.8	- 3.0	- 2.0	- 1.4
	(± 38)	(± 25)	(± 17)	(± 12)	(± 8)
0.4	+ 3.5	+ 2.6	+ 1.8	+ 1.3	+ 1.0
	- 6.0	- 3.6	- 2.3	- 1.6	- 1.1
	(± 30)	(± 20)	(± 14)	(± 10)	(± 7)
0.5	+ 3.0	+ 2.1	+ 1.5	+ 1.1	+ 0.8
	- 4.5	- 2.8	- 1.9	- 1.3	- 0.9
	(± 24)	(± 16)	(± 11)	(± 8)	(± 5)
0.6	+ 2.5	+ 1.8	+ 1.3	+ 0.9	+ 0.7
	- 3.5	- 2.2	- 1.5	- 1.0	- 0.7
	(± 19)	(± 13)	(± 9)	(± 6)	(± 4)
0.7	+ 2.1	+ 1.5	+ 1.0	+ 0.7	+ 0.5
	- 2.7	- 1.7	- 1.2	- 0.8	- 0.6
	(± 15)	(± 10)	(± 7)	(± 5)	(± 4)
0.8	+ 1.6	+ 1.1	+ 0.8	+ 0.6	+ 0.4
	- 2.0	- 1.3	- 0.9	- 0.6	- 0.4
	(± 12)	(± 8)	(± 6)	(± 4)	(± 3)
0.9	+ 1.1	+ 0.8	+ 0.5	+ 0.4	+ 0.3
	- 1.3	- 0.8	- 0.6	- 0.4	- 0.3
	(± 8)	(± 5)	(± 4)	(± 3)	(± 2)

For each entry, the first two digits are the upper and lower bounds on $|H|$, in dB.

Digits in parentheses are the bounds on ϕ , in degrees.

(Data compiled from formulas in Ref. 3, p. 202.)

Table 2

**90% confidence limits on coherence function measurements.
Entries in table are min, max limits.**

Measured value of coherence function	Number of Averages				
	16	32	64	128	256
0.4	.15, .59	.23, .54	.28, .50	.32, .47	.34, .45
0.5	.25, .67	.33, .63	.39, .59	.42, .57	.45, .55
0.6	.36, .74	.45, .71	.50, .68	.53, .66	.55, .64
0.7	.50, .81	.57, .78	.61, .76	.64, .75	.66, .73
0.8	.65, .88	.70, .86	.74, .84	.76, .83	.77, .82
0.9	.81, .94	.85, .93	.87, .92	.88, .92	.88, .91

Section 4:

Experimental examples using the coherence function

Example 1: Using the coherence function to monitor a transfer function experiment

The purpose of the experiment indicated by Figure 3 is to demonstrate that transfer function measurements are susceptible to contamination by signals other than the intended input, and to show how the coherence function reveals the existence of such signals.

We measured the relative mechanical inertance of a small structure: a 5" by 7" by .062" printed circuit board. Inertance is acceleration/force, and this quantity was measured as a transfer function by connecting an accelerometer output to Channel B and the pseudo-random driving signal to Channel A. (A small shaker converted the electrical driving signal to mechanical force.) Modal vibration resonances are clearly indicated in the inertance spectrum, which is displayed in Figure 3(a) along with the coherence function. Except for zero frequency, where the accelerometer output is zero, the coherence function is unity nearly everywhere else, indicating a good measurement environment (in the sense of signal/noise ratio). One exception occurs at the 100 Hz resonance. Here, the coherence function has decreased to about 0.83, indicating a signal/noise ratio of $.83/1 - .83$, or about 7 dB (see appendix for using the coherence function to calculate a S/N ratio). This effect oc-

curred because, at this frequency, the accelerometer output was low, approaching the noise level of the analyzer.

Without changing anything else, we made a minor modification before running the experiment again. This was to drop a small screw into a hole in the test board. The mass of the screw only slightly lowered the resonant frequencies, but its looseness caused it to vibrate against the board as excitation was applied. Within the experimental structure we thus created a non-linear element which converted (that is, smeared) some of the input energy to other frequencies. As Figure 3(b) shows, not a lot of energy was converted, since the coherence function is generally high. However, at just those places where we would expect signal/noise problems—where the response signal is small—the effect of the smeared energy is apparent. An interesting exception is the strong 260 Hz resonance, which is only lightly affected; this means the energy generated by the vibrating screw is not uniformly distributed in frequency.

The principal use of the coherence function in measurements of this sort is to alert the person performing the measurement that there **is** a signal/noise problem and to give him information about the frequencies and magnitudes of its occurrence.

Figure 3.

Vibration spectrum of 5" x 7" printed circuit board.

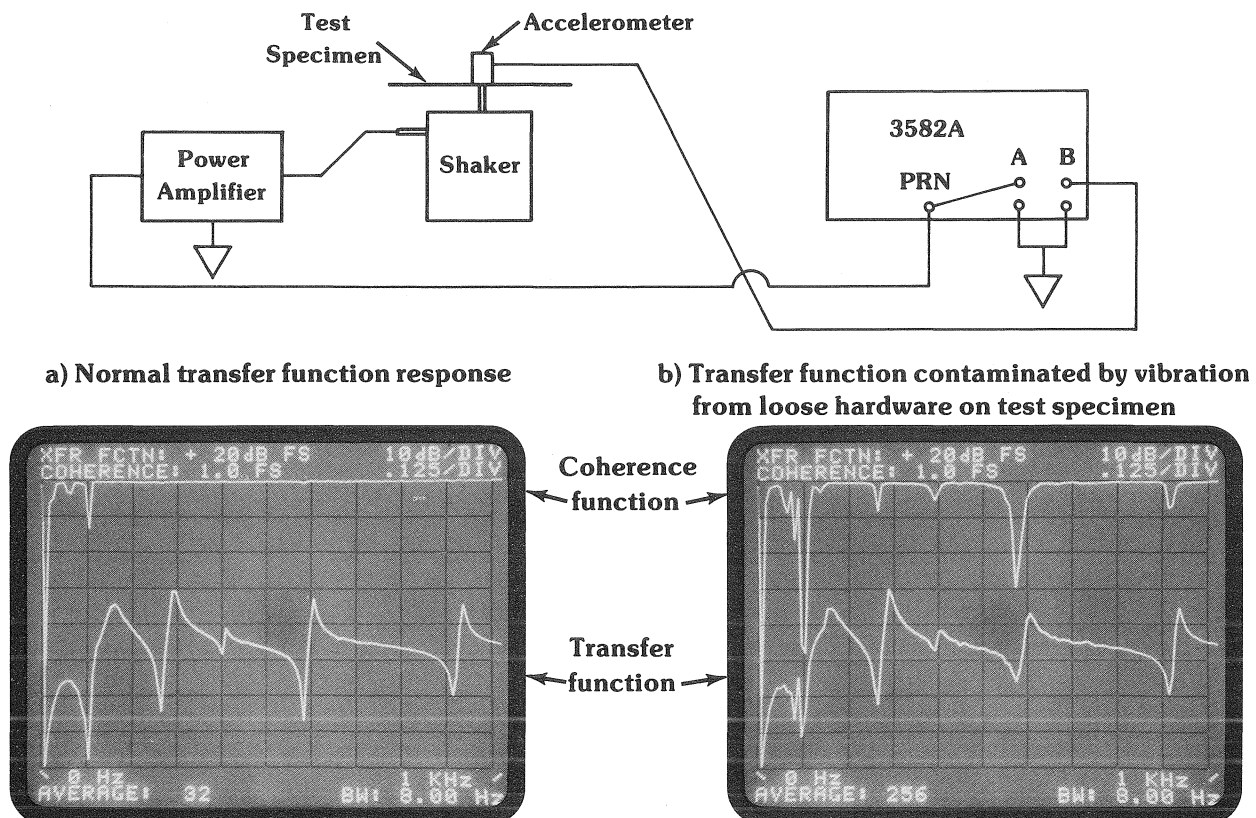

c) Test setup. The “loose hardware,” a 10-32 screw inserted through a hole in the test board, is visible in right front corner of board. Device on top of analyzer is power supply for accelerometer.

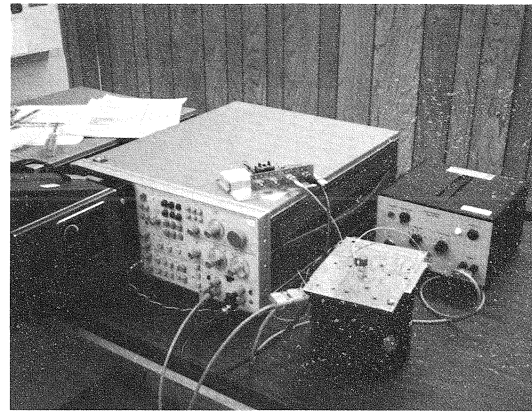

Experiment 2: Dual-input system with random signals

The main purpose of the experiment of Figure 4 is to show how the coherence function is used to separate the individual effects of input signals which are combined in a system to form a common output signal, and thus to reveal input-output causal relations.

Sometimes simple spectrum analysis can be used to trace cause-effect relations. The output signal of a system and an input which is thought to be causally related to it may share common spectral components or lines; this usually means a causal relation unless another input **also** has the same components, which makes the situation a lot more complicated! However, when the spectra are continuous (without individual lines), as is the case with random signals, one cannot usually deduce causality by looking for common components. One purpose of this experiment is to illustrate that point.

In the system shown in Figure 4, there are two identical noise sources, X and Y, connected to the inputs. In

this case, “identical” means that the two power spectra are flat and have the same amplitude, so that they couldn’t be distinguished with a spectrum analyzer. Inside the box representing the system, each signal is passed through a simple filter and then the two are combined linearly to form the output signal. The filters, low-pass and high-pass, are carefully matched in cutoff frequency and gain, with the result that the output signal Z **also** has a flat spectrum, even though it is the combination of two filtered inputs. Figure 4(a) shows the spectra of one of the inputs and the output, while Figure 4(b) shows the filter transfer functions, their -3 dB frequencies being equal. Assuming that we have access only to the terminals X₁, Y₁, and Z, and that we can’t disconnect the sources, how do we determine the causal relation of each source to the output? In fact, how can we tell that this system is any different from one in which there is no frequency dependence in the combining process?

Figure 4.

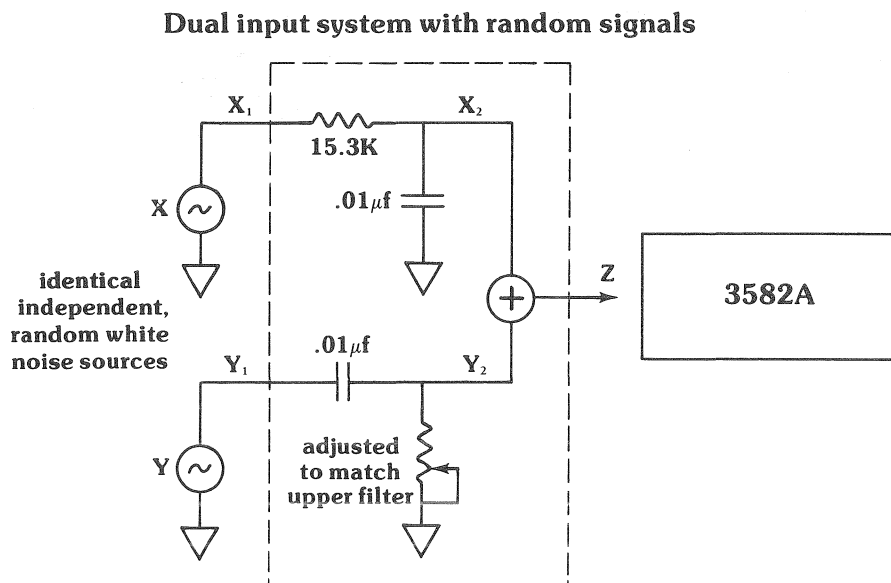

The measured coherence functions, shown in Figure 4(c), provide the answer to these questions. Remembering from the discussion in Section 2 that the measured coherence function of a random process must be averaged to improve the statistical accuracy (which is why the display is ragged; see Table 2), we can interpret the results as follows. First, the low-pass signal X is the dominant output term at low frequencies, since the coherence function is nearly unity there. The same is true for signal Y at high frequencies. At **any** frequency, the two coherence functions add to unity, confirming the statement in Section 2 that the coherence function represents the fraction of output power attributable to the input in question. Note that both functions are equal to 0.5 at the common crossover frequency 1040 Hz (which is often called the half-power point). Finally, the answer to the second question is that the coherence functions for a system with no frequency dependence would be flat, at values which represent each input's contribution to the output power.

a) Noise spectra at one input (X_1) and output Z . The other input (Y_1) has an identical spectrum.

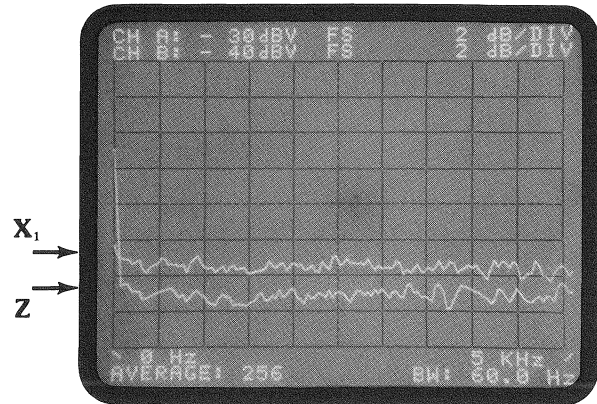

b) Measured filter transfer functions.

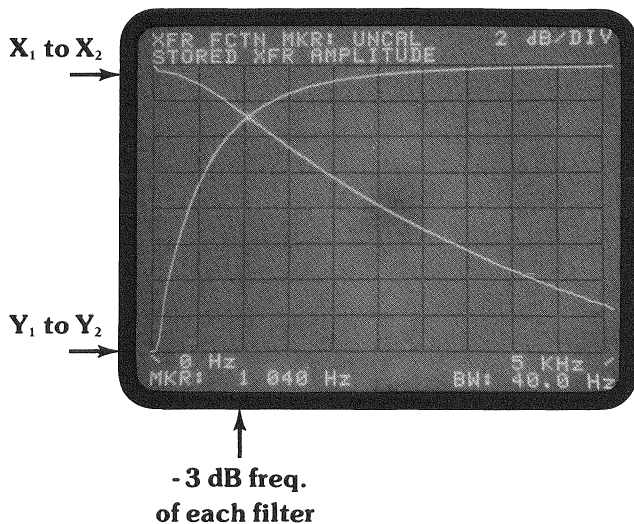

c) Coherence functions between each input and the output.

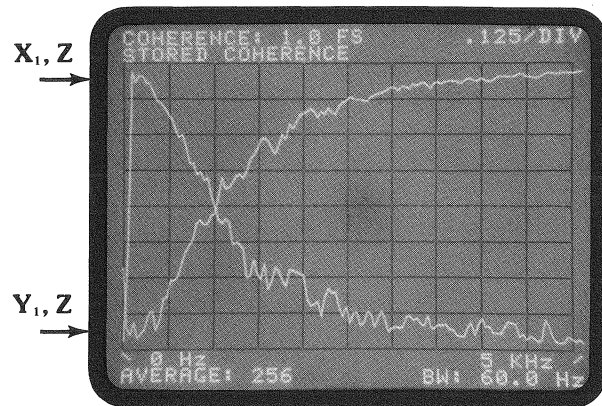

Appendix:

Definitions and interpretations

Linear spectra and power spectra

Figure 5 is the model of a linear, single-input system much like that of Figure 1 except the various signals and the transfer function are shown both as functions of frequency and of time. Also, a single disturbing signal (or noise source) is shown adding to the total output signal Y. This represents the simplest form of the situation described in Section 1, in which the output is contaminated with energy not directly related to the input.

The time-function and frequency-function equivalent forms of a signal are related by the Fourier transform. For instance,

$$X(f) = F[x(t)] \equiv \int_{-\infty}^{\infty} x(t)e^{-j2\pi ft} dt$$

The frequency function $X(f)$ is called a linear spectral function, or linear spectrum because it corresponds to the first order time function $x(t)$. There is another spectral function corresponding to the power function $x^2(t)$. (We assume, for convenience, that $x(t)$ is a voltage across a 1 ohm resistor.) This function is the "auto" power spectrum (that is, self-power) and it is defined as

$$\text{auto power spectrum} = G_{xx}(f) \equiv X(f) \cdot X^*(f)$$

That is, the linear spectrum $X(f)$ multiplied by its complex conjugate. Notice that the power spectrum has no imaginary term; its phase is zero at all frequencies.

There is another kind of power spectrum which reveals, in a sense, the relation between **two** signals, say $X(f)$ and $Y(f)$. This is called the cross-power spectrum, and it is defined similarly:

$$\text{cross-power spectrum} = G_{yx} \equiv Y(f) \cdot X^*(f)$$

In contrast to the auto power spectrum $G_{xx}(f)$, the cross power spectrum is generally complex (phase $\neq 0$).

The cross-power spectrum is central to both the coherence function and the method used by the 3582A to calculate transfer functions.

Figure 5.

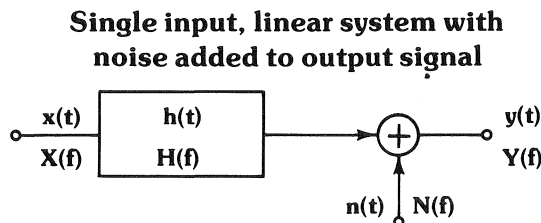

Defining the coherence function

With the concept of a power spectrum in hand, the formal definition of the coherence function, applied to the situation of Figure 5 can be given:

$$\text{coherence function} = \gamma^2 \equiv \frac{|G_{yx}(f)|^2}{G_{xx}(f) \cdot G_{yy}(f)}$$

(From now on, we will drop the independent variable f from the expressions to keep them tidier, but it is assumed.)

The expression for γ^2 , the coherence function, can be examined from at least two points of view which provide useful interpretation and insight.

The coherence function as a power ratio

Note that the output spectrum Y contains both input- and noise-related components: $Y = HX + N$. The power spectrum, G_{yy} , can be expressed using these components:

$$G_{yy} = YY^* = (HX + N)(HX + N)^* = |H|^2 G_{xx} + G_{NN} + HG_{xN} + H^* G_{Nx}$$

We can also form an expression for the cross-power term:

$$G_{yx} = YX^* = (HX + N)X^* = HG_{xx} + G_{Nx}$$

Now, before using these expanded forms to construct an expression for the coherence function, we must reason as follows: since X and N are assumed to be independent, uncorrelated signals, they do not have any common, synchronous components. Therefore, cross-power terms involving these signals (such as G_{Nx}) must be zero. Using this argument, the expanded expression for the coherence function simplifies:

$$\gamma^2 = \frac{(HG_{xx})(HG_{xx})^*}{G_{xx}(|H|^2 G_{xx} + G_{NN})} = \frac{|H|^2 G_{xx}}{|H|^2 G_{xx} + G_{NN}}$$

In words, this interprets the coherence function as

$$\gamma^2 = \frac{\text{output power due to the input}}{\text{total output power}}$$

That is, γ^2 equals the fraction of the output power attributable to the input signal. (Any nonlinearity in the system may convert some of the input signal to energy at other frequencies, but the coherence function treats this energy as noise.) It follows that $\gamma^2 G_{yy}$ is the output power related to the input, and that $(1 - \gamma^2) G_{yy}$ is the noise component of the output power. Therefore, the system signal-to-noise ratio is $\gamma^2 / (1 - \gamma^2)$. Note that this is not the overall S/N ratio, but the S/N ratio at **each** frequency, a very useful aid in interpreting measurement results.

The coherence function as a correlation coefficient

Another useful interpretation of the coherence function is in terms of the statistical measure called the correlation coefficient.

Let's assume we have N values of each of the complex, zero-mean variables X and Y. (In reality, this is the situation in the 3582A after making N two-channel transforms; **at one frequency**, X_i and Y_i represent the linear spectral values of the ith transform of the signals in channels A and B, respectively.) Estimates of two statistical quantities defined for such variables are

1) the variance:
$$\sigma_x^2 = \frac{1}{N} \sum_{i=1}^N X_i X_i^*$$

$$\sigma_y^2 = \frac{1}{N} \sum_{i=1}^N Y_i Y_i^*$$

2) the covariance:
$$C_{yx} = \frac{1}{N} \sum_{i=1}^N Y_i X_i^*$$

Another quantity is the normalized correlation coefficient, defined in terms of (1) and (2) as

3) the normalized correlation coefficient:

$$\rho_{yx} = \frac{C_{yx}}{\sigma_y \sigma_x}$$

Now the 3582A makes these same calculations (1) and (2) in the course of determining the coherence function. That is, at any one of the 256 analysis frequencies, it calculates

channel A auto spectrum =
$$G_{xx} = \frac{1}{N} \sum_{i=1}^N X_i X_i^* = \sigma_x^2$$

The first two references are clearly-written, illustrated technical articles dealing with several aspects (including coherence functions) of random-process measurement. The last is probably the standard text dealing with this subject matter. It is clear and well organized so that it may be used for reference as well as study.

1) "Effective Measurements using Digital Signal Analysis," by Peter R. Roth, IEEE SPECTRUM, April, 1971

And similarly, channel B auto spectrum = $G_{yy} = \sigma_y^2$ and the cross-power spectrum = $G_{yx} = C_{yx}$.

From these results and the previous definition of the coherence function, we see that $\gamma^2 = \rho_{yx}^2$.

Thus, we can interpret the coherence function as the squared correlation coefficient of the two spectra X and Y **at each analysis frequency**.

The use of the cross-power spectrum to calculate transfer functions

On page 2 the use of the cross-power spectrum as a means for calculating transfer functions was mentioned. The reason for this technique will now be outlined.

Referring to Figure 1, it is customary to derive the transfer function H by calculating the output/input ratio Y/X. This is fine, since $Y = HX$, **except** for the situations where Y contains some noise or other contaminating signal. In this case (see Figure 5), the output/input ratio is $(HX + N)/X$, which is not equal to H, nor can any amount of signal averaging cause it to approach the true value of H.

A remedy for this problem can be found as follows. Multiplying numerator and denominator by X^*/X^* , we have

$$\frac{Y}{X} \frac{X^*}{X^*} = \frac{G_{yx}}{G_{xx}} = \frac{HXX^* + NX^*}{XX^*} = \frac{HG_{xx} + G_{nx}}{G_{xx}}$$

As before, we reason that the term G_{nx} is the cross-power between X and N, which are assumed to be uncorrelated. Averaging will thus produce an estimate of this term which tends to zero. Thus, the true value of H is recoverable, even in the presence of system noise, through the use of the cross-power spectrum and the auto spectrum of the input.

2) "How to Use the Spectrum and Coherence Function," by Peter R. Roth, SOUND AND VIBRATION, January, 1971.

3) "Random Data: Analysis and Measurement Procedures," by Julius S. Bendat and Allan G. Piersol, Wiley-Interscience, 1971